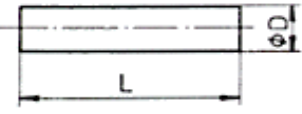
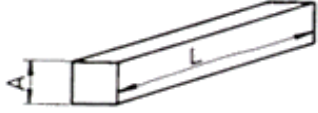
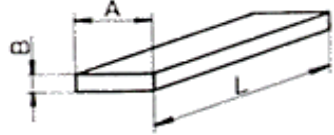
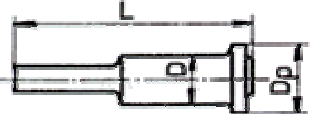
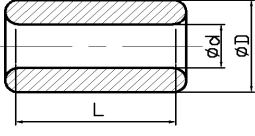
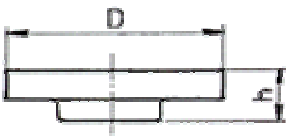
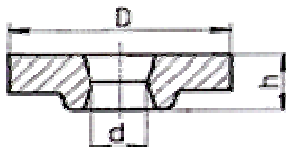
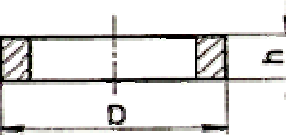
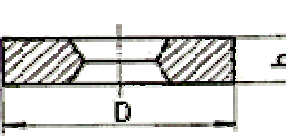
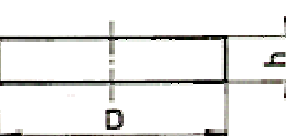
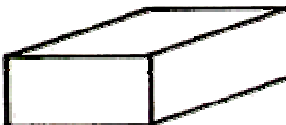

# Výkovky - výrobné možnosti

# Forgings - production possibilities

# Schmiedeteile - Produktionsmöglichkeiten

TVAR FORM FORM	NÁZEV NAME BENENNUNG	MAX. ROZMĚR MAX. SIZE MAX. ABMESSUNGEN	MAX. HMOTNOST MAX. WEIGHT MAX. GEWICHT
			CS - NORM
	<b>PODÉLNÉ</b> kruhového průřezu <b>LONGITUDINAL</b> with the circular section <b>LÄNGLICHE</b> mit dem Kreisquerschnitt	D = 280 mm L = 4000 mm	2 000 kg  ČSN 429011
	<b>PODÉLNÉ</b> čtvercového průřezu <b>LONGITUDINAL</b> with the square section <b>LÄNGLICHE</b> mit dem Quadratquerschnitt	A = 260 mm L = 4000 mm	2 000 kg  ČSN 429011
	<b>PODÉLNÉ</b> obdélníkového průřezu <b>LONGITUDINAL</b> with the rectangular section <b>LÄNGLICHE</b> mit dem rechteckigen Querschnitt	Max. průřez Max. section Max. Querschnitt 600 cm <sup>2</sup> Max. poměr Max. ratio Max. Verhältnis A : B = 7 L = 4000 mm	2 000 kg  ČSN 429011
	<b>VŘETENA</b> s napěch. koncem různých tvarů a provedení <b>SPINDLES</b> with the upset and of various shapes and types <b>SPINDELN</b> mit dem eingsetampfen ENDE, von verschieden Formen und Ausführungen	D = 280 mm L = 4000 mm	2 000 kg
	<b>DUTÁ TĚLESA</b> <b>HOHLKÖRPER</b>	D = 360 mm d = 160 mm L = 700 mm	450 kg

TVAR FORM FORM	NÁZEV NAME BENENNUNG	MAX. ROZMĚR MAX. SIZE MAX. ABMESSUNGEN	MAX. HMOTNOST MAX. WEIGHT MAX. GEWICHT
			CS - NORM
	<b>KOTOUČE</b> kola, spojky, příruby - plné <b>DISCS</b> wheels, couplings, flanges - full <b>SCHEIBEN</b> Räder, Kupplungen, Flansche - volle	D = 800 mm h / D = 0,3 - 0,8	750 kg ČSN 429012
	<b>KOTOUČE</b> kola, spojky, příruby - děrované <b>DISCS</b> wheels, couplings, flanges - perforated <b>SCHEIBEN</b> Räder, Kupplungen, Flansche - gelochte	D = 800 mm d = 170 mm h / D = 0,3 - 0,8	750 kg ČSN 429012
	<b>KROUŽKY volně</b> <b>RINGS free</b> <b>RINGE</b>	D = 1000 mm h = 490 mm	5 - 800 kg ČSN 429013
	<b>KOTOUČE</b> děrované <b>DISCS</b> perforated <b>SCHEIBEN</b> gelochte	D = 780 mm h = dle váhy = according to the weight = nach Gewicht	800 kg ČSN 429012
	<b>KOTOUČE</b> plné <b>DISCS</b> full <b>SCHEIBEN</b> volle	D = 780 mm h = dle váhy = according to the weight = nach Gewicht	800 kg ČSN 429012
	<b>KOSTKY - BLOKY</b> <b>CUBES - BLOCKS</b> <b>WÜRFEL - BLOČKES</b>	- rozměry dle hmotnosti - dimensions according to the weight - Abmessungen nach Gewicht	800 kg ČSN 429011

TVAR FORM FORM	NÁZEV NAME BENENNUNG	MAX. ROZMĚR MAX. SIZE MAX. ABMESSUNGEN	MAX. HMOTNOST MAX. WEIGHT MAX. GEWICHT
			CS - NORM
	<b>ZÁPUSTKOVÉ VÝKOVKY</b> <b>DROP FORGINGS</b> <b>GESENKSCHMIEDESTÜCKE</b>	D min = 150 mm D max = 260 mm h min = 30mm h max = 120 mm d min = 75 mm	min. 5 kg max. 25 kg  ČSN 429030.1
			
	<b>ZÁPUSTKOVÉ VÝKOVKY</b> <b>DROP FORGINGS</b> <b>GESENKSCHMIEDESTÜCKE</b>	D min = 150 mm D max = 260 mm h min = 30mm h max = 120 mm	min. 5 kg max. 25 kg  ČSN 429030.1

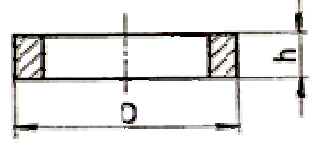
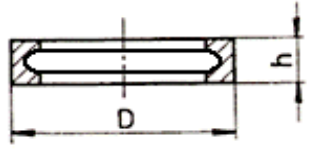
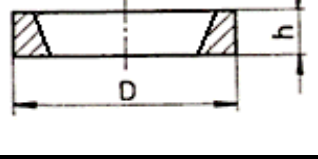
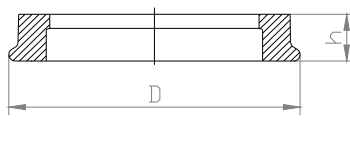
TVAR FORM FORM	NÁZEV NAME BENENNUNG	MAX. ROZMĚR MAX. SIZE MAX. ABMESSUNGEN	MAX. HMOTNOST MAX. WEIGHT MAX. GEWICHT
			CS - NORM
	<b>ROZVÁLCOVANÉ KROUŽKY</b> <b>ROLLED - OUT RINGS</b> <b>RINGENAUSWALZEN</b>  <b>TVAROVÉ KROUŽKY</b> <b>SHAPED RINGS</b> <b>GEFORMTE RINGE</b>	Dmax = 2500 mm h = 390 mm	1300,- kg
			
			
	<b>ROZVÁLCOVANÉ OBRUČE</b> <b>ROLLED WHEELS</b> <b>GEWALZTE RADREIFEN</b>	Dmax = 1350 mm h = 160 mm	450,- kg